

REINHOLD ENVIRONMENTAL Ltd.



2012 APC Round Table & Expo Presentation

July 16-17, 2012, in Baltimore, MD / Hosted by Duke Energy, Entergy,
FirstEnergy, Southern Company & TVA

All presentations posted on this website are copyrighted by Reinhold Environmental, Ltd (RE). Any unauthorized downloading, attempts to modify or to incorporate into other presentations, link to other websites, or obtain copies for any other uses than the training of attendees to RE's Conferences is expressly prohibited, unless approved in writing by RE or the original presenter. RE does not assume any liability for the accuracy or contents of any materials contained in this library which were presented and/or created by persons who were not employees of RE.



POTENTIAL MATS COMPLIANCE STRATEGIES

1. Dry Sorbent Injection

- Increased ACI Effectiveness for Hg Removal
- HCl Mitigation

2. Added or Modified SCR Catalyst for Hg Oxidation

DSI for MATS Compliance

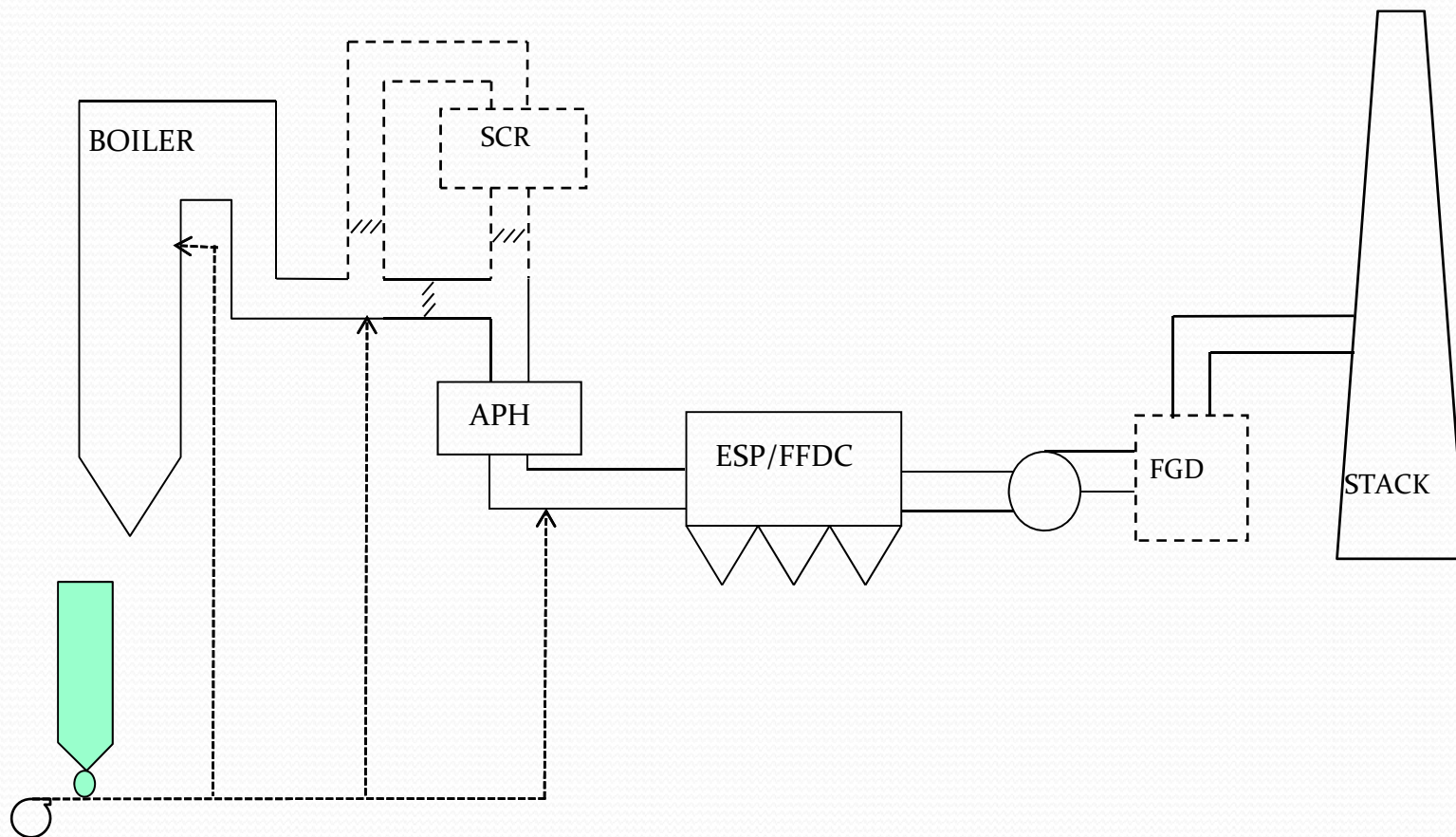



POTENTIAL DSI IMPACTS FOR MATS COMPLIANCE

- Pre ESP
 - Resistivity
 - Mass Loading
 - Ash Handling
 - Ash Disposal
- Pre APH
 - Hg Impacts
 - Pluggage Concern
- Pre SCR
 - Catalyst Impacts
 - Hg Impacts (HCl)
- Boiler
 - Pluggage
 - Deposits



POTENTIAL DSI BENEFITS TO PLANT SYSTEMS

- Reduced Duct Corrosion
- Reduce APH Pluggage
- Potential to lower APH out temps
 - Heat Rate Savings
 - Lower ESP inlet Temps
- SCR Min Op Temp/ Turndown benefit
- FGD Wastewater Benefit – HCl Reduction

BENEFIT OF HCL REMOVAL w/ DSI

Basic FGD Mass Balance

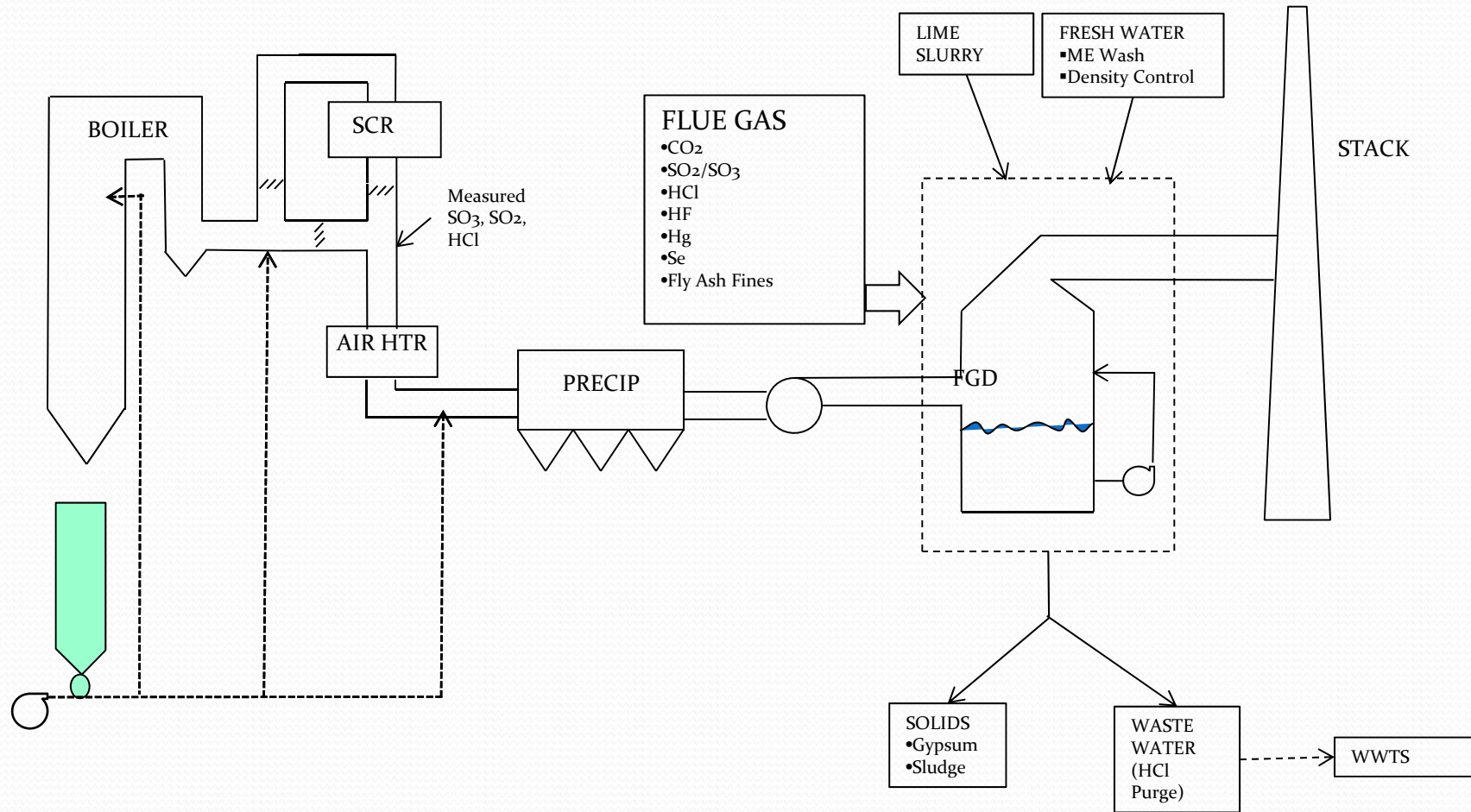



SCR CATALYST FOR HG OXIDATION

Potential Problems from Additional Catalyst

- Added DP
- Added SO₃ & Associated Impacts
- Catalyst Deactivation Trends more Important

Potential Benefits from Additional Catalyst

- More DeNO_x Potential
- Possible NH₃ Slip Reduction